

# Fuel System

## CARBURETORS

The following carburetor types are fitted:

- Weber 34 DCHD 4 on engine 115 C.005;
- Weber 34 DCS 2 and 34 DCS 4 on engine 118 B.000.

### WEBER 34 DCHD 4 CARBURETOR SETTING DATA

ITEM	Primary Throat	Secondary Throat
Bore . . . . .	1.339" (34 mm)	1.339" (34 mm)
Venturi . . . . .	.984" (25 mm)	.984" (25 mm)
Main jet . . . . .	.051" (1.30 mm)	.055" (1.40 mm)
Idling jet . . . . .	.020" (0.50 mm)	.027" (0.70 mm)
Air correction jet . . . . .	.088" (2.25 mm)	.090" (2.30 mm)
Starting jet . . . . .	.059" (1.50 mm)	
Starting air jet . . . . .	.197" (5 mm)	
Accelerator pump jet . . . . .	.027" (0.70 mm)	
Accelerator pump recirculation jet . . . . .	shut off	
Idling air jet . . . . .	.075" (1.90 mm)	
Needle valve housing . . . . .	.069" (1.75 mm)	
Float . . . . .	.63 oz (18 gr)	
Float level: — distance of float from the face of cover (vertical, without gasket) . . . . .	.197" to .216" (5 to 5.5 mm)	
— float travel . . . . .	.335" (8.5 mm)	

### SETTING DATA OF WEBER 34 DCS 2 AND 34 DCS 4 CARBURETORS

ITEM	Primary Throat	Secondary Throat
Bore . . . . .	1.339" (34 mm)	1.339" (34 mm)
Venturi . . . . .	.866" (22 mm)	.866" (22 mm)
Main jet . . . . .	.041" (1.05 mm)	.041" (1.05 mm)
Air correction jet . . . . .	.079" (2 mm)	.079" (2 mm)
Idling jet . . . . .	.016" (0.40 mm)	.016" (0.40 mm)
Idling air jet . . . . .	.031" (0.80 mm)	.031" (0.80 mm)
Accelerator pump jet . . . . .	.016" (0.40 mm)	.016" (0.40 mm)
Starting jet . . . . .	.031" (0.80 mm)	
Starting air jet . . . . .	.059" (1.50 mm)	
Needle valve housing . . . . .	.069" (1.75 mm)	
Float . . . . .	.63 oz (18 gr)	
Float level: — distance of two float halves from the face of cover (vertical, without gasket) . . . . .	.256" (6.5 mm)	
— float travel . . . . .	.335" (8.5 mm)	

## WEBER CARBURETOR TYPE 34 DCHD 4

### Description (Figs. 88 and 89).

The Weber 34 DCHD 4 carburetor is of the downdraft, dual-barrel, compound design.

The first carburetor stage is directly under the mechanical control of the accelerator which operates the primary throttle valve (12) via a system of links and levers.

The second throat, instead, will turn in automatically, beyond the driver's control, thanks to a device consisting of a vacuum chamber (19) which contains a diaphragm (44) being connected to the secondary throat throttle (37) via a system of links and levers.

The secondary throttle (37) begins opening as soon as vacuum in the first throat is such as to overcome, through the passage (38), the force of the spring opposing the diaphragm (44) which, in turn, causes the lever on the secondary throttle (37) spindle to rotate via a rod.

As the secondary throttle is opening, vacuum in the second throat affects also the port at the primary Venturi restriction, thus ensuring the full opening of the secondary throttle whenever the engine may so require.

Provision is made for the secondary throat throttle to close through a mechanical device in spindles of the primary and secondary throttles (fig. 87).

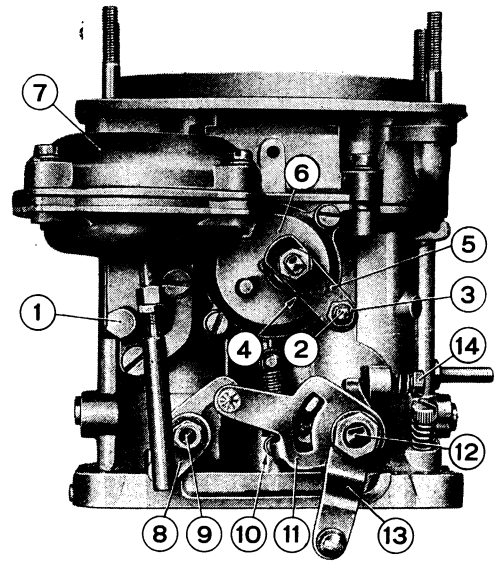

Fig. 87. - Weber 34 DCHD 4 carburetor to suit engine 115C.005.

1. Cable sheath retaining screw - 2-3. Choke control cable retaining screw and nut - 4. Lever return spring - 5. Choke control lever - 6. Vacuum device cover - 7. Vacuum device - 8. Secondary throat throttle control lever - 9. Secondary throat throttle spindle - 10. Sector return spring - 11. Sector for release and return of lever (8) - 12. Primary throat throttle spindle - 13. Primary throat throttle control lever - 14. Screw for idle adjustment of primary throat throttle.

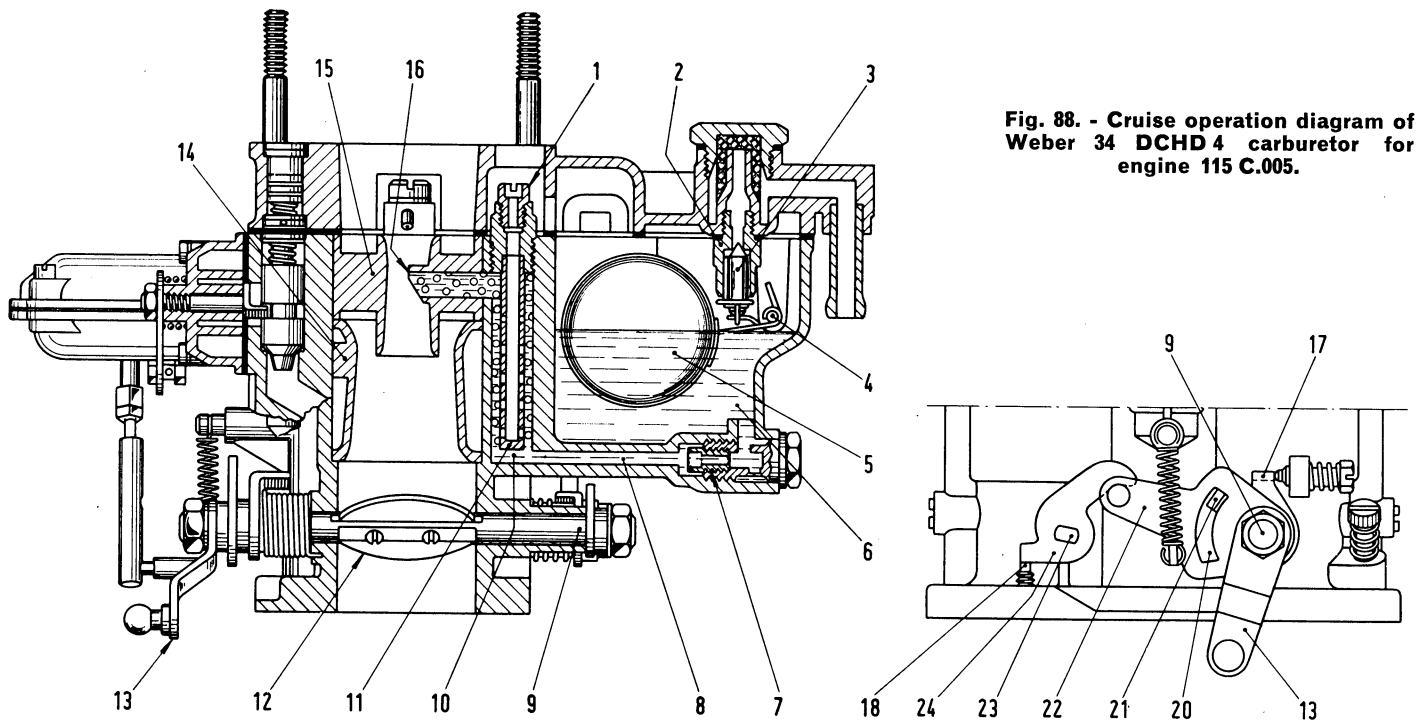

Fig. 88. - Cruise operation diagram of Weber 34 DCHD 4 carburetor for engine 115 C.005.

1. Air correction jet - 2. Needle valve - 3. Valve needle - 4. Pivot pin - 5. Float - 6. Bowl - 7. Main jet - 8. Main jet-to-emulsion well passage - 9. Primary throttle spindle - 10. Emulsion well - 11. Emulsion tube - 12. Primary throttle - 13. Primary throttle control lever - 14. Primary Venturi - 15. Auxiliary Venturi - 16. Discharge tube - 17. Lever stop sector - 18. Secondary throttle stop adjusting screw - 20. Slot for lug (21) - 21. Drag lug for sector (22) - 22. Sector for release and return of lever (24) - 23. Secondary throttle spindle - 24. Secondary throttle return lever.

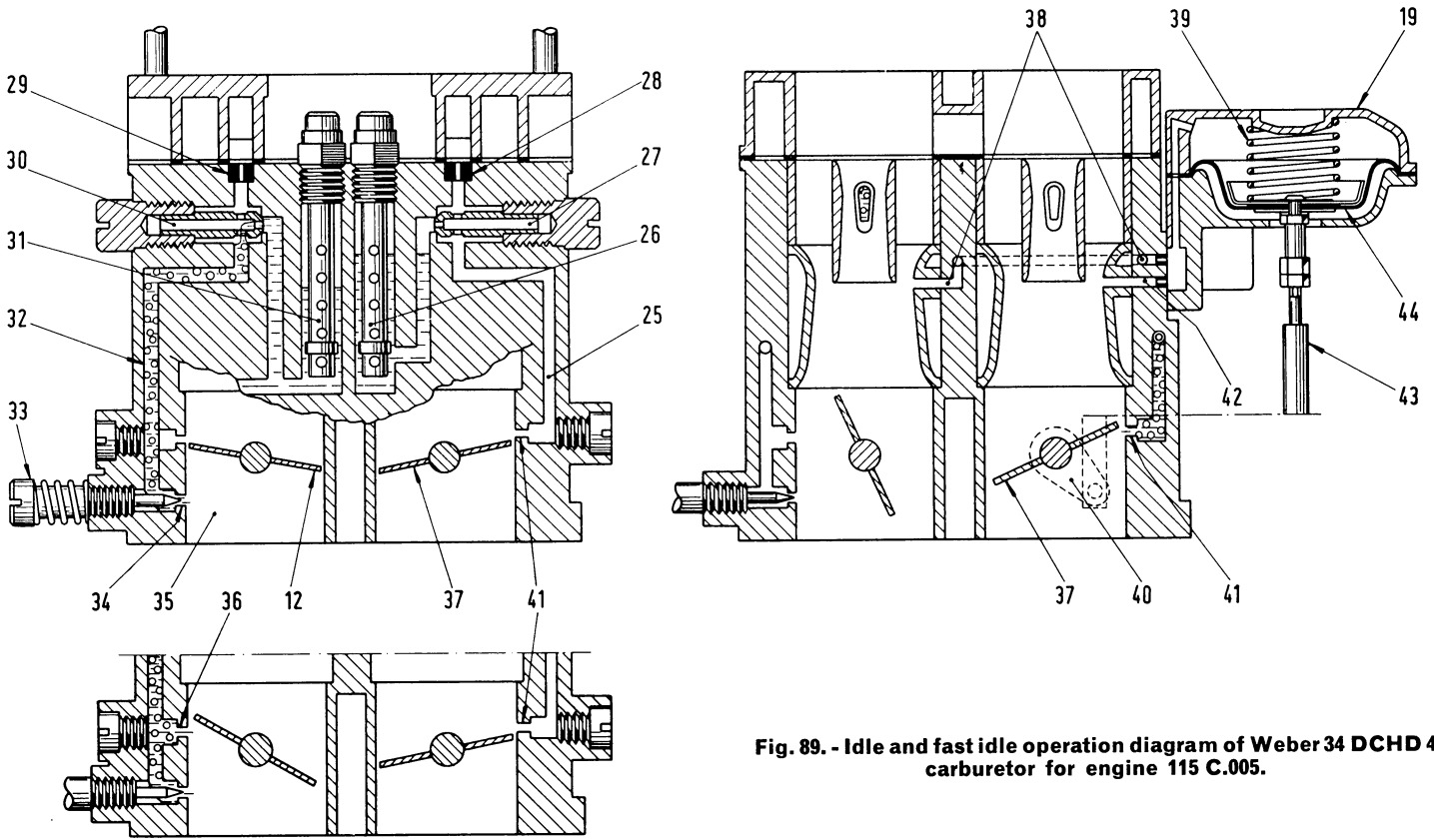

Fig. 89. - Idle and fast idle operation diagram of Weber 34 DCHD 4 carburetor for engine 115 C.005.

12. Primary throttle valve - 19. Vacuum chamber - 25. Secondary throat idle transfer port passage - 26. Secondary emulsion tube - 27. Secondary idle jet - 28. Secondary idling air calibrated bushing - 29. Primary idling air calibrated bushing - 30. Primary idle jet - 31. Primary emulsion tube - 32. Idle passage - 33. Idle adjusting screw - 34. Idling feed orifice - 35. Primary throat - 36. Primary throat idle transfer port - 37. Secondary throttle valve - 38. Vacuum device port and passage at primary throat - 39. Spring - 40. Secondary throttle control lever - 41. Secondary throat idle transfer port - 42. Vacuum device port at secondary throat - 43. Secondary throttle control rod - 44. Vacuum device diaphragm.

### Accelerator Pump (fig. 90).

This pump is of the plunger type.

When the primary throttle is closed, the lever (52) raises the rod (51) and thus the plunger (49) causing

fuel to be drawn from the bowl (6) through the ball valve (47) into the pump cylinder.

When the primary throttle (12) is opened, the lever (53) depresses the lever (52) working idle on the secondary spindle (23). As a result, the rod is released

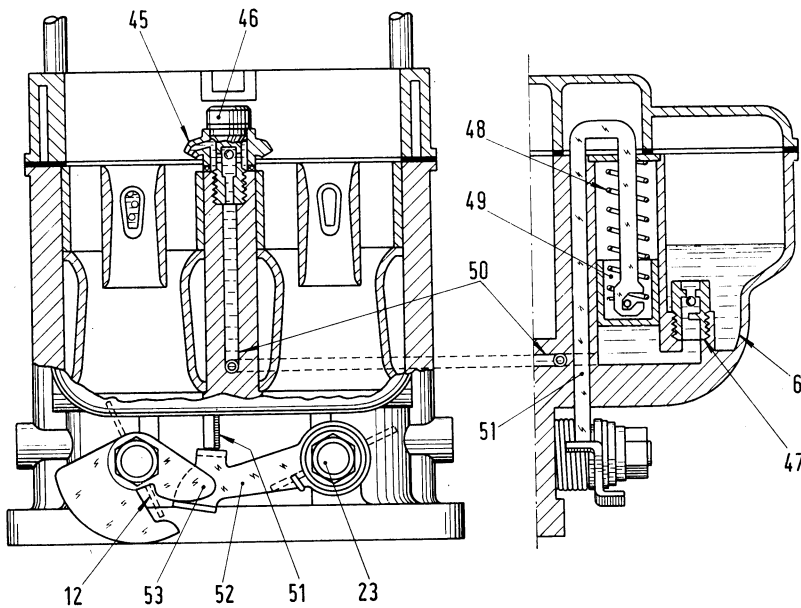

Fig. 90. - Power operation diagram of Weber 34 DCHD 4 carburetor for engine 115 C.005.

6. Bowl - 12. Primary throttle valve - 23. Secondary throttle spindle - 45. Accelerator pump jet - 46. Delivery valve - 47. Suction valve - 48. Spring - 49. Accelerator pump plunger - 50. Delivery passage - 51. Plunger rod - 52. Rod control lever, idler - 53. Pump control lever, primary.

